

产品型号: 15EDGKAM

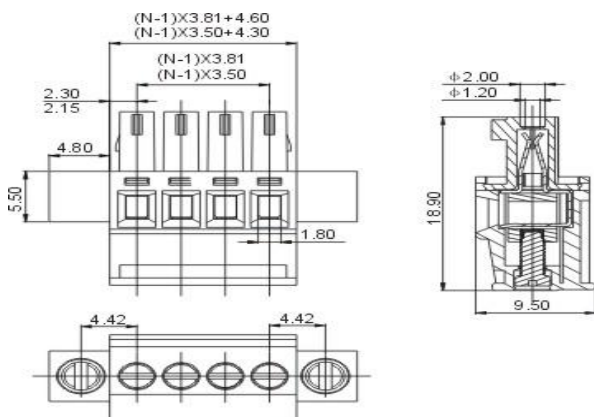

使用材质

绝缘塑件	PA66, UL94V-0
端子材料	黄铜, 镀镍
触点材料	磷青铜
螺 丝	M2, 钢, 镀Cr3+钝化彩锌

电气性能

参考标准	UL	IEC
额定电压	300V	250V
额定电流	8A	10A
线径范围	28-16AWG	0.5-1.5mm ²
耐电压	AC2000V / 1 Min	
绝缘电阻	5000M Ω / 1000V	
接触电阻	20 M Ω	

机械性能

温度范围	-40 $^{\circ}$ C~+105 $^{\circ}$ C
瞬时温度	+250 $^{\circ}$ C, 5秒
剥线长度	7 mm
扭 矩	0.2Nm (1.7Lb-In.)
位 数	2P-24P
间 距	3.5mm 3.81mm

产品订购指南:

